

Technical Data Sheet TI-F55

Locking Units of the KFHS series 18 to 50 mm

(with DGVU Test Certificate)

For a detailed functional description, see the Technical Information TI-F10.
 Further important information can be found in the Operating Manual BA-F55.

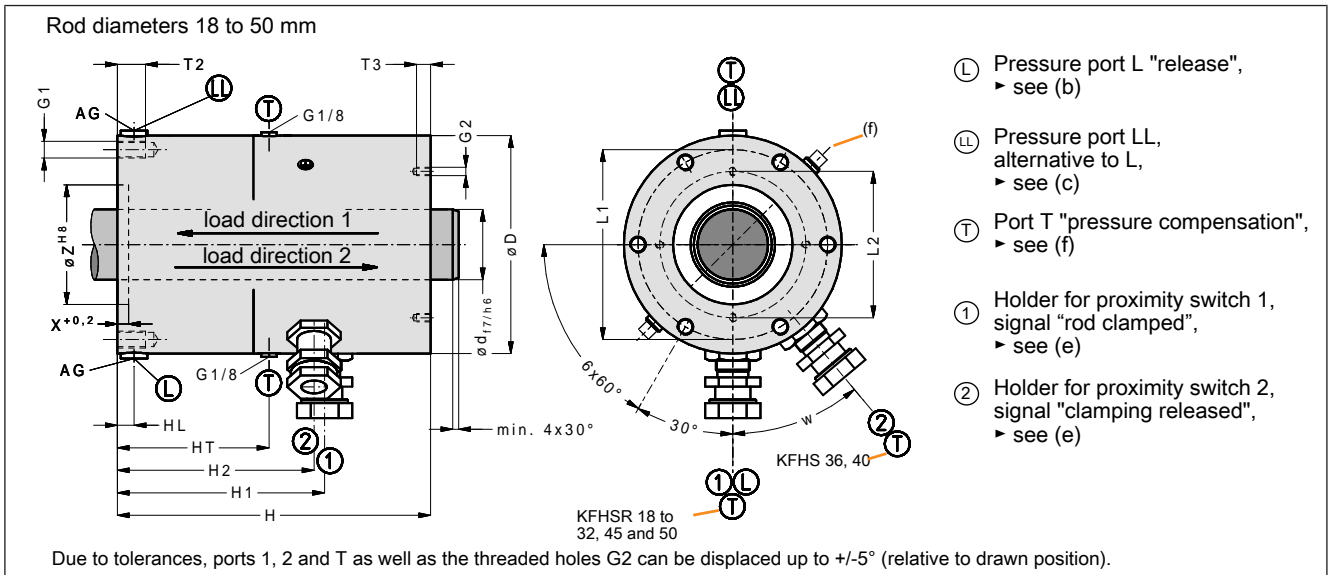

Fig. 1: Dimensions of the KFHS Locking Unit (download of CAD data from the Internet: www.sitema.com)

Type	ID no. (order no.)	(a) (b)										(d)										
		d	M	p	D	H	L1	L2	T2	T3	G1	G2	Z	X	AG	V	HL	H1	H2	HT	w	Wt.
		mm	kN	bar	mm	mm	mm	mm	mm	mm			mm	mm		cm ³	mm	mm	mm	mm	mm	kg
KFHS 18	KFHS 018 70	18	5	70	71	137	60	34	12	8	6xM6	4xM4	30	4	G1/8	6	29	105	98	68	45°	4
KFHS 25	KFHS 025 70	25	10	100	95	140	82	44	15	10	6xM8	4x M6	50	6	G1/8	11	19	89.5	83	62	35°	6
KFHS 28	KFHS 028 70	28	17	100	115	178	96	63	18	10	6xM10	4xM6	60	6	G1/4	18	20	118	112	94	30°	12
KFHS 32	KFHS 032 70	32	17	100																		
KFHS 36	KFHS 036 70	36	25	100	138	200	115	80	18	14	6xM10	4xM6	70	6	G1/4	28	19	109.5	119	96	30°	19
KFHS 40	KFHS 040 70	40	25	100																		
KFHS 45	KFHS 045 70	45	37.5	100	155	223	135	96	20	14	6xM12	4xM6	85	8	G1/4	39	20	147.5	140	108	30°	26
KFHS 50	KFHS 050 70	50	37.5	100																		

Subject to modification without prior notice

- (a) M is the admissible load the mass to be secured exerts on the KFHS Locking Unit. The holding force with a dry or hydraulic-oil wetted rod is at least $2 \times M$ but does not exceed $4 \times M$.
- (b) Pressure p is required to release the clamping. The permissible operating pressure is 160 bar.
- (c) On delivery, pressure port LL is plugged by a plug screw. It may be used as an alternative to pressure port L and is useful for filling or air bleeding the pressure chamber. We recommend connecting an auto-bleeder to the free port (see *Technical Information TI-Z10*).
- (d) Hydraulic operating volume
- (e) Proximity switch holders are mounted for standard inductive proximity switches: M12 x 1, nominal switching distance 2 mm, flush mountable, NO (normally open); exception: KFHS 18 and 25: M8 x1 with 1.5 mm nominal switching distance. For easier mounting, the proximity switch holders have a depth stop and are preset to the correct depth at delivery. The proximity switches only need to be inserted to the stop and then clamped. The proximity switches are not included in the standard scope of delivery but are available as accessories.
- (f) The T ports compensate internal volume changes during switching. For this "breathing" process, at delivery, one of the ports T is fitted with an air filter. In a dry and clean factory environment, this filter offers sufficient protection against dust etc. The other port T is plugged with a plug screw. If moisture or aggressive media can be sucked up, replace the filter by an unpressurized line which leads to a clean atmosphere (e.g. a clean and unpressurized container). In this case, the other port T must be sealed with the delivered plug screw.
- (g) The lock plates keep the clamping system open if the unit is not yet mounted. They have to be removed after mounting.
- (h) The surface of the housing parts is ZnNi coated.

Technical Data Sheet TI-F55

Locking Units of the KFHS series 56 and 60 mm

(with DGUV Test Certificate)

For a detailed functional description, see Technical Information TI-F10.
 Further important information can be found in the Operating Manual BA-F55.

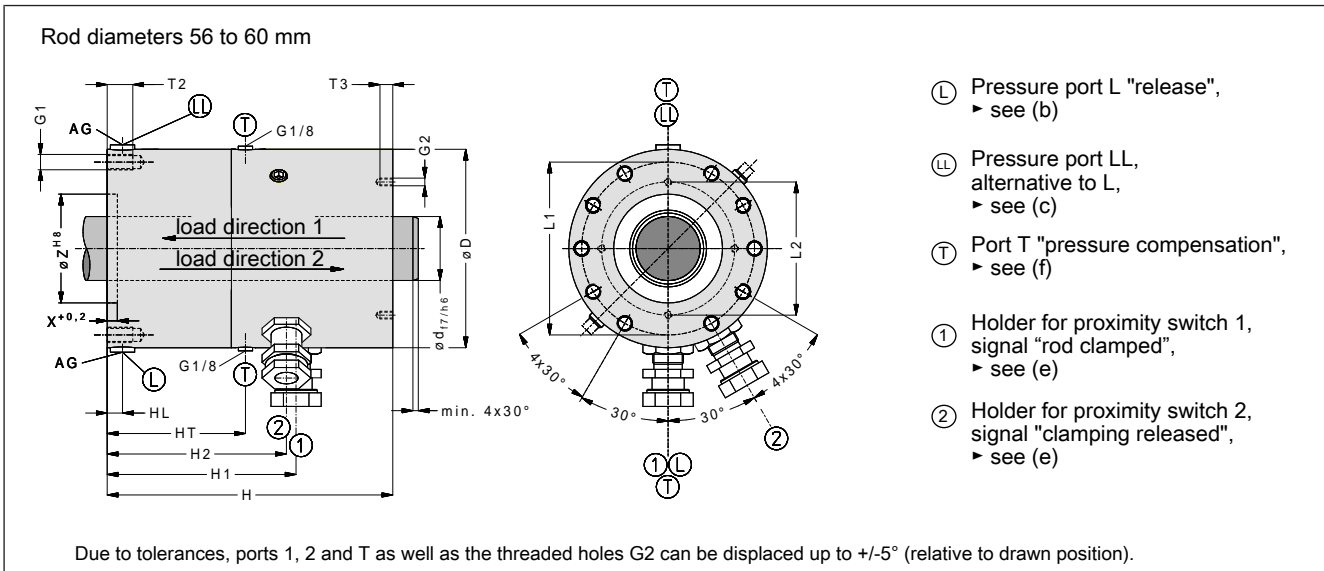

Technical Data Sheet TI-F55

Locking Units of the KFHS series 70 to 125 mm

(with DGUV Test Certificate)

For a detailed functional description, see the Technical Information TI-F10.

Further important information can be found in the Operating Manual BA-F56.

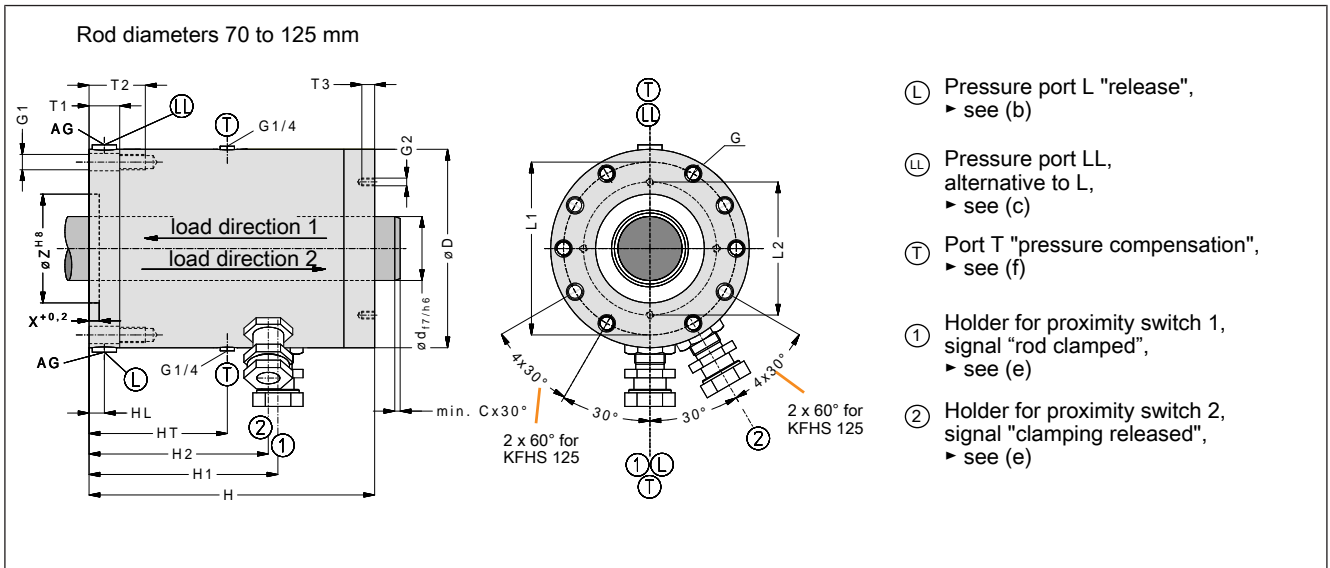

Fig. 3: Dimensions of the KFHS Locking Unit (download of CAD data from the Internet: www.sitema.com)

Type	ID no. (order no.)	d mm	(a) (b)			D	H	L1	L2	T1	T2	T3	G1	G2	Z	X	AG	V cm ³	HL	H1	H2	HT	Wt. kg
			C kN	M bar	p																		
KFHS 70	KFHS 070 70	70	4	75	100	225	315	195	160	26	56	16	10x M16	4x M8	110	10	G1/4	68	13	192	185	236	80
KFHS 80	KFHS 080 70	80																					
KFHS 90	KFHS 090 70	90	5	125	130	260	393	225	175	30	65	20	10x M20	4x M10	125	10	G3/8	95	15	221	214	283	127
KFHS 100	KFHS 100 70	100																					
KFHS 125	KFHS 125 70	125	5	165	100	350	416	300	250	40	90	20	6x M30	4x M12	230	10	G3/8	150	24	244.5	235	336	240

Subject to modification without prior notice

- (a) M is the admissible load the mass to be secured exerts on the KFHS Locking Unit. The holding force with a dry or hydraulic-oil wetted rod is at least 2 x M but does not exceed 4 x M.
- (b) Pressure p is required to release the clamping. The permissible operating pressure is 160 bar.
- (c) On delivery, pressure port LL is plugged by a plug screw. It may be used as an alternative to pressure port L and is useful for filling or air bleeding the pressure chamber. We recommend connecting an auto-bleeder to the free port (see *Technical Information TI-Z10*).
- (d) Hydraulic operating volume
- (e) Proximity switch holders are mounted for standard inductive proximity switches: M12 x 1, nominal switching distance 2 mm, flush mountable, NO (normally open); exception: KFHS 18 and 25: M8 x1 with 1.5 mm nominal switching distance. For easier mounting, the proximity switch holders have a depth stop and are preset to the correct depth at delivery. The proximity switches only need to be inserted to the stop and then clamped.

- The proximity switches are not included in the standard scope of delivery but are available as accessories.
- (f) The T ports compensate internal volume changes during switching. For this "breathing" process, at delivery, one of the ports T is fitted with an air filter. In a dry and clean factory environment, this filter offers sufficient protection against dust etc. The other T port is plugged with the delivered plug screw. If moisture or aggressive media can be sucked up, replace the filter by an unpressurized line which leads to a clean atmosphere (e.g. a clean and unpressurized container). In this case, the other port T must be closed with the delivered plug screw.
- (g) The surface of the housing parts is ZnNi coated.

Technical Information

1 Purpose

The KFHS Locking Unit has been designed to hold static loads.

The Locking Unit is certified for the holding of static loads in accordance with the testing principle GS-HSM-02 of the DGUV (German Social Accident Insurance).

2 Axial play

The admissible load M is held free from axial play in load directions 1 and 2.

3 Operating conditions

The Locking Unit has been designed for operation in a dry and clean environment.

If a line is connected to port T, operation in adverse environmental conditions is also possible. Please contact SITEMA if you have an environment with heavy contamination (particles, grease, grinding dust, or chips) or extreme temperatures.

The permitted surface temperature is -20°C to +60 °C.

Viscous lubricants and grease may reduce the holding force.

4 Pressure fluid - hydraulic fluid

Use high-quality HM hydraulic fluid according to ISO 11158 (or HLP hydraulic fluid according to DIN 51524-2). Other pressure fluids may be used only in consultation with SITEMA.

5 Choosing the right type

In the Technical Data Sheets, you find the values of the admissible load M for the different types. M must be higher than the static weight force acting on the rod.

The certification bodies request that the holding force of the Locking Unit is at least 2 times the admissible load M.

If you have a safety-related application, also observe the information in the *Technical Information TI-F40 - DGUV Test Certificate*.

6 Requirements of the clamping rod and fastening elements

The Locking Unit will only operate correctly if the clamping rod has a suitable design.

Requirement	Diameter	Value
ISO tolerance zone	all	f7 or h6
Induction hardened	all	min. HRC 56
Surface hardening depth	ø to 30 mm	min. 1 mm
	ø over 30 mm	min. 1.5 mm
Surface roughness	all	Rz = 1 to 4 µm (Ra 0.15 to 0.3 µm)
Protection from corrosion	all	e.g. hard chromium plating: 20 ± 10 µm 800 - 1000 HV
Lead-in chamfer rounded	ø 18 to 80 mm	min. 4 x 30°
	ø over 80 to 180 mm	min. 5 x 30°
	ø over 180 to 380 mm	min. 7 x 30°

Table 4: Clamping rod requirements

The rod may never greased.

Manufacturers of cylinder piston rods or rods for linear ball bearings usually offer suitable clamping rods.

The actual holding force of the Locking Unit is higher than the admissible load (M) indicated on the data sheets and dimensional drawings. It will not be higher than 4 times this value, however.

Accordingly, the fastening elements taking over the load (rod and its linkage, etc.) have to be dimensioned for at least 4 x M. This maximum force can occur when braking during a motion.

In case of overload, the rod slips, normally causing no damage to rod and Locking Unit.

In any case, the basic rod material needs to have sufficient strength. In the case of compression-loaded rods, the buckling resistance must be observed.

7 Lock plates of KFHS 18 to 60

The KFHS types 18 to 60 are delivered with red lock plates. The lock plates keep the clamping open and enable a quick installation. For mounting, it is possible to slide the Locking Unit directly over the rod. It is not necessary to connect a temporary pressure supply.

IMPORTANT: The lock plates have to be removed after mounting.

Please see the operating manual for further details.

8 Actuation

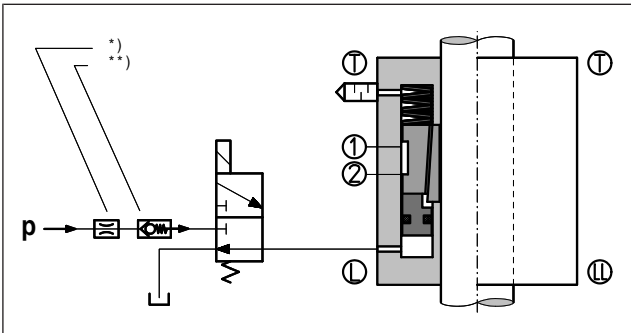

Fig. 4: Schematic actuation diagram

*	If impact noises are audible when pressurizing the unit, they can be suppressed by installing a throttle in the p-line.
**	If the pressure is not sufficiently constant (e.g. pressure drop at the beginning of a downward stroke), we recommend a check valve in the pressure connection.

In most cases it is recommended to implement the actuation as shown in the figure above.

During every operational cycle, the 3/2-way valve which releases the clamping is actuated electrically.

In any other operational condition, as well as in cases of power failure, the Locking Unit engages, holds the rod and/ or brakes the load. Likewise, the load is secured when the supply line breaks.

To prevent problems, a movement of the rod should only be permitted if proximity switch 2 signals "clamping released".

For a quick response time, the following preconditions must be met:

- quick controller
- short line distances
- quick valve response times
- large valve and line cross-sections

9 Status monitoring by proximity switches

The proximity switches monitor the Locking Unit operating state. The proximity switches send the following signals to the machine control system:

Proximity switch	Signal	Purpose
1	Load secured	Enabling access to the danger zone.
2	Clamping released	Enabling drive movement in load direction.

To check the correct functioning of the proximity switches, the switching of the signals has to be tested. There is an error if both proximity switches indicate a signal or no signal at the same time (apart from short overlapping periods during switching).

The machine control system must process the signals from the proximity switches correctly.

9.1 Integration of the Locking Unit into the machine control system

Here is an example for integrating the Locking Unit into the machine control.

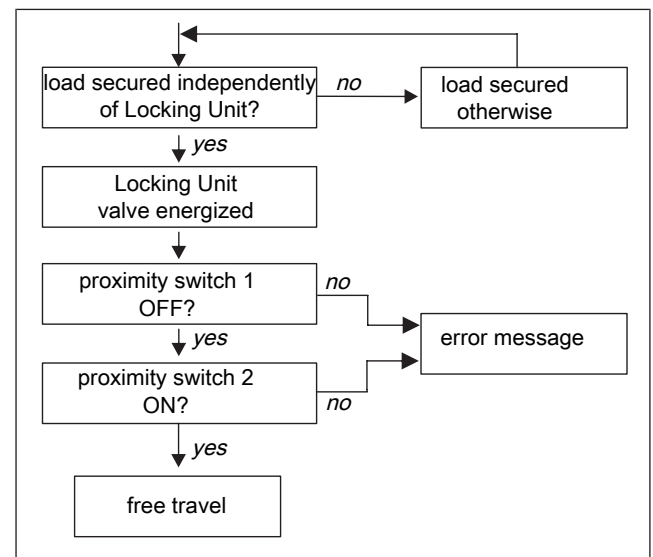
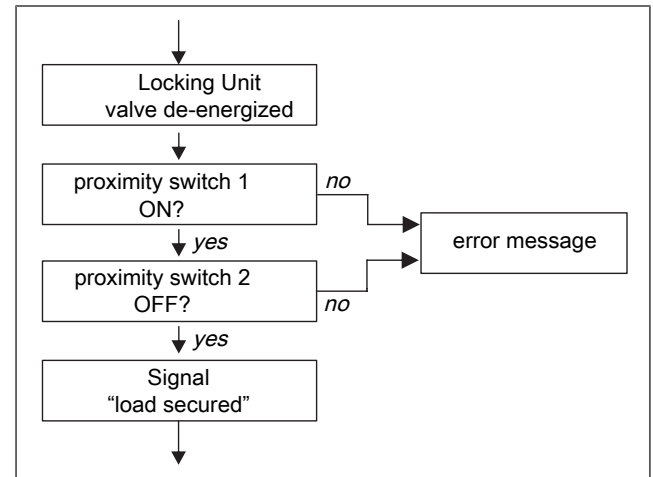

10 Risk assessment

It must be ensured that the dimensions and arrangement of Locking Units used in safety-relevant applications meet the requirements of EN ISO 12100:2010 and also comply with any further standards and regulations applicable for the intended use. The Locking Unit alone principally cannot be a complete safety solution. It is however suitable to be part of such a solution. Furthermore, all attachments and connections have to be dimensioned correspondingly. This is the task of the machine manufacturer/operator.

11 Regular performance tests

A performance test of the Locking Unit must be carried out at regular intervals. Regular checking is the only way to ensure that it will operate safely in the long run.

Please see the Operating manual for further details.

12 Maintenance

Maintenance is limited to the regular performance tests. Should the Locking Unit cease to comply with the required characteristics, the safety for working with the machine or system may no longer be given. In this case the Locking Unit must be immediately and professionally repaired by SITEMA.

To ensure the function as safety-related component, any repair or refurbishing must be carried out by SITEMA. SITEMA cannot take any responsibility for repairs by another party.

13 DGUV Test Certificate

The KFHS and KFHSR Locking Units from SITEMA carry the DGUV Test Certificate. After thorough examination, the test and certification body of the German Social Accident Insurance (DGUV) issued the DGUV Test Certificate.

You find this DGUV Test Certificate and further information in the *Technical Information TI-F40* (download from www.sitema.com).